

# Liberty Pumps®

## NEW!

## ProVore™ 380



US Patent #s  
7,520,736, 7,563,082  
& 7,159,806

**Shipped with  
Clear Construction Cover**



Clear disposable cover protects the system during masonry work and rough-in.

### **Residential Simplex Grinder System**

**1 hp  
2" Discharge**

**Compact simplex system -  
designed for residential  
sewage applications**

**Perfect for basement  
bathroom additions and  
remodeling projects**

**Available in 115V or 230V**

**Fully assembled from factory**

#### **Features:**

- Robust system features a compact heavy-duty polyethylene basin and cover
- System can be installed above or below floor level
  - 41 gallon capacity
- Patented V-Slice® cutter technology shreds difficult solids such as feminine products, rags, towels and wipes that can jam solids-handling pumps
- Easy access cover with QuickTree® technology – allows for quick float removal and servicing
- Heavy-duty integrated rubber gaskets on covers
- Secure 16 bolt cover – standard on all models. Passes 10' stack test

innovate. evolve.

# ProVore™ 380

## QuickTree® Technology

### Features:

- QuickTree® technology allows easy access and removal of switches without disturbing pump or plumbing.
- Integrated rubber seals permanently attached to cover.
- Unique cord seal technology integrated into the inspection cover.
- Shallow basin design (24") for easier installation in difficult soil/bedrock locations.
- Large 41 gallon capacity for longer pump cycles.
- Integrally molded torque stops secure the pump in its proper position.
- Integrally molded anti-flotation collar.
- Durable polyethylene construction.
- Completely assembled.

## QuickTree® Technology

### Integral Rubber Seals



Unique integrated cord seal technology and permanent rubber cover gaskets.

US Patent #s  
7,520,736, 7,563,082  
& 7,159,806

### Models:

MODEL	HP	VOLTS	PHASE	AMPS	DISCHARGE	CORD LENGTH	WGT. LBS.
P382XPRG101	1	115	1	12	2"	10'	87
P382XPRG102	1	230	1	6	2"	10'	87

See specific PRG-Series literature for complete pump performance and specifications.  
For 25' power cord add "-2" suffix to model number. Example: P382XPRG101-2

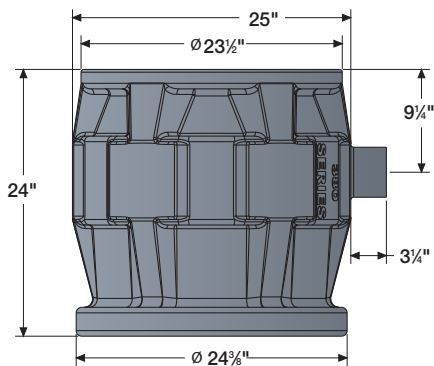

# ProVore™ 380-Series 24" x 24" – 41 Gallons

## 1 hp. Residential Grinder Package

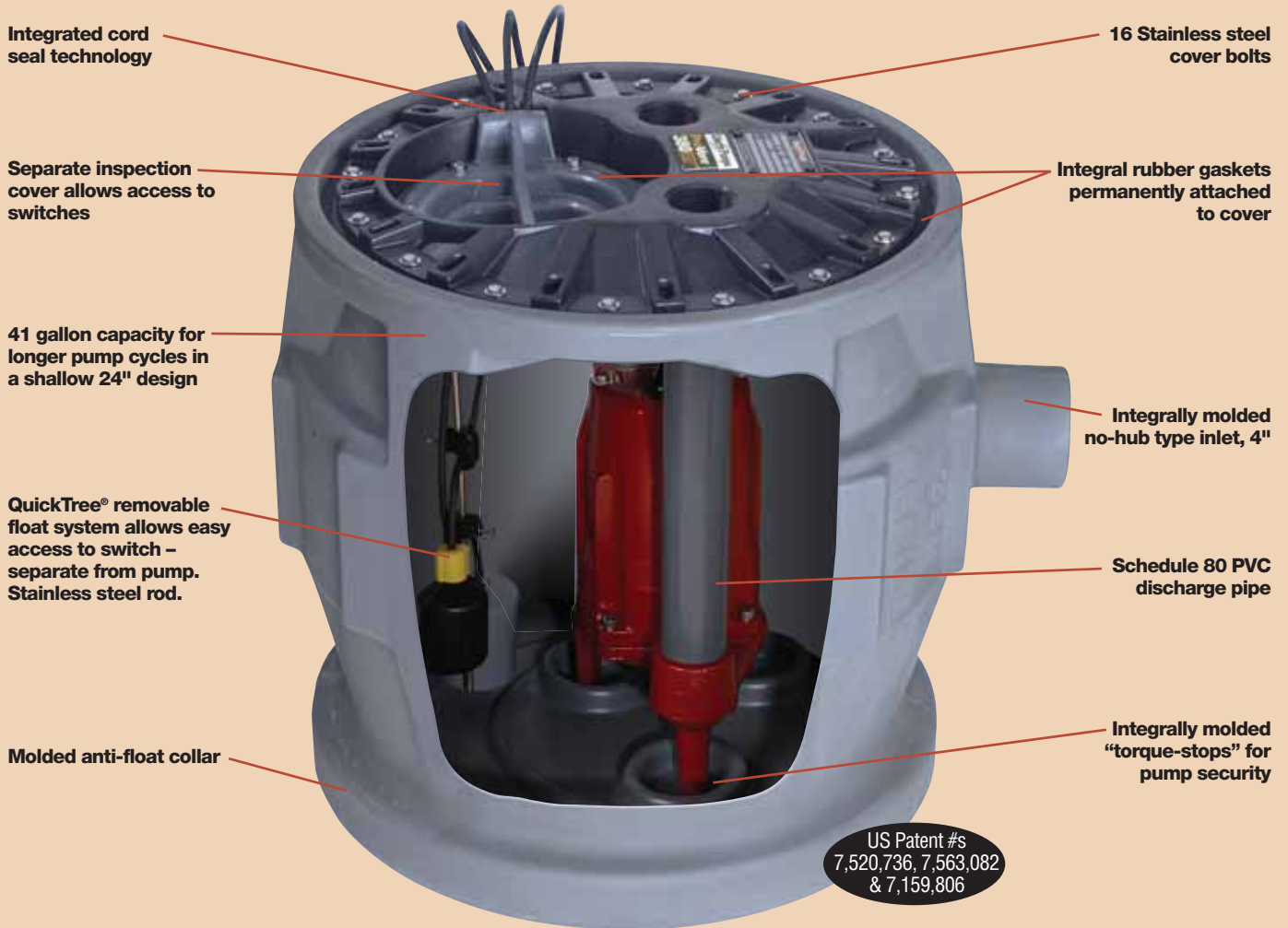

### Performance Curve 60 Hz.

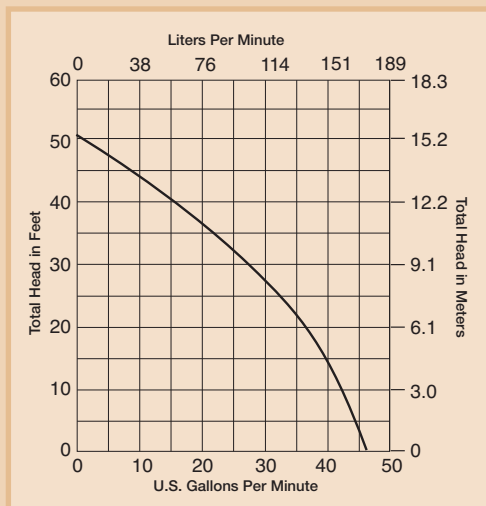

### IAPMO Listed Basin

The ProVore380 Basin is specifically designed to pass a 10' stack test and is IAPMO listed.



vate. evolve.

**Riser allows burial of the ProVore™380 System up to a maximum depth of 18" below grade.**

A convenient chamber for all your pump's electrical and piping connections – out of sight and below grade. Riser simply slides over the sealed 380 system. Cover is retained by 4 stainless steel bolts and features a twist-lock design with provision for padlock to deter unwanted entry.

**Specifications:**

**Weight: 28 lbs.- (Riser and Cover)**

**Riser Height: 18-3/4"**

**Total Height with Cover: 20-1/2"**

**Diameter: 32"**

MODEL	DESCRIPTION
AR18	Access Riser
AC18	Access Riser Cover (Environmental Green)
ARC18	Kit, Access Riser with Cover
ARCKIT115	Kit, Access Riser with Cover and 2" installation accessories - 115V
ARCKIT230	Kit, Access Riser with Cover and 2" installation accessories - 230V
IKIT2-115	Installation Kit 2", 115V
IKIT2-230	Installation Kit 2", 230V

# Optional Access Riser



Liberty's installation kits provide all the components for a professional installation inside the riser. Kit includes: JB-Series wiring box and hardware, check valve with a disconnect union feature, coupling and elbows (PVC piping not included). Kits available in 2" discharge and vent size only.

# ProVore™380-Series Alarmed System



Now, have the assurance of early warning in the event of a high-level condition with an alarm option installed from the factory! We do the work for you by mounting the alarm float in the basin at its proper level – no need to even open the cover! Simply mount the alarm panel in its desired location, supply power and connect the alarm float leads!



**ALM-2 (pictured)**  
Indoor 115V Alarm with 9 volt Battery Back-up

## How to Order:

Alarm Model	Add Suffix	Ordering Example
ALM-2	/A2	P382XPRG101/A2

Alarm float is pre-set at proper level in basin.  
Alarm panel packaged with unit.